

Model 1515D Pressure Chamber Instrument



PMS Instrument Company

1725 Geary Street SE ♦ Albany OR 97322 ♦ USA

Phone: (541) 704-2299 ♦ FAX: (541) 704-2388

info@pmsinstrument.com

www.pmsinstrument.com

OPERATING INSTRUCTIONS

FOR A COMPLETE LIST OF PICTURE TUTORIALS AND VIDEOS - WWW.PMSINSTRUMENT.COM



Instrument Specifications:

Maximum Instrument Operating Pressure: 100 BAR/ 1500 PSI

Chambers Construction: Solid Stock Stainless Steel

Maximum Portable Tank Pressure: 207 BAR/ 3000 PSI

Weight: 35 Pounds / 16 Kg



- 1) A lower canopy, shaded leaf is covered with foil-laminate bag.
- 2) The water in the stem is under tension.
- 3) The stem is cut and the leaf with bag is sealed inside chamber.
- 4) Pressure is applied to the leaf until water appears at the cut surface.

How it Works

Simply put, the pressure chamber is just a device for applying pressure to a leaf or small shoot. Most of the leaf is inside the chamber, but the cut end of the stem (the petiole) is exposed outside the chamber (see illustration above). The amount of pressure it takes to cause water to appear at the cut surface of the petiole tells you how much tension the leaf is experiencing on its water supply. A high value of pressure means a high value of tension and a high degree of water stress. These stress levels vary within different species. The unit of pressure most commonly used is Bar (1 Bar = 14.5 PSI).

What is Plant Moisture Stress?

The water status of plants, and how to measure it, has received much attention in recent years and for good reason. Plant moisture stress (PMS), or plant water potential, indicates the demand for water within a plant. A PMS measurement indicates the water status of a plant from the “plant’s point of view.” PMS also tells how the environment affects the plant. High PMS levels cause many physiological processes, such as slowing or stopping photosynthesis. Conditions producing high PMS reduce plant growth and may eventually result in the death of the plant. PMS information can be used to evaluate the plants need for water or how well it is adapted to its environment.

Why Measure Plant Moisture Stress?

Measuring PMS gives an indication of a plants ability to grow and function and can be used as a guide for managing the plants moisture environment so as to improve growth and crop yield. Air temperature, wind speed, humidity, and soil moisture are all integrated by the plant into one single value — PMS. A measure of PMS thus gives an evaluation of the moisture status of a plant from the plants point of view. It is an excellent tool for aiding in irrigation scheduling for crop plants such as almond, walnut, prunes, cotton, and wine grapes or for any application where plant growth is managed such as in nurseries, greenhouses, seedlings or reforestation.

Principle of Operation

The pressure chamber can be thought of as measuring the “blood pressure” of the plant — except that for plants it is water rather than blood. And the water is not pumped by a heart using pressure, but rather pulled with a suction force as water evaporates from the leaves. Water within the plant mainly moves through very small inter-connected cells, collectively called xylem, which are essentially a network of pipes carrying water from the roots to the leaves. The water in the xylem is under tension. As the soil dries or humidity, wind or heat load increases, it becomes increasingly difficult for the roots to keep pace with evaporation from the leaves. This causes the tension to increase. Under these conditions you could say that the plant begins to experience “high blood pressure.”

Since tension is measured, negative values are typically reported. An easy way to remember this is to think of water stress as a “deficit.” The more the stress the more the plant is experiencing a deficit of water. The scientific name given to this deficit is the “water potential” of the plant. The actual physics of how the water moves from the leaf is more complex than just “squeezing” water out of a leaf, or just bringing water back to where it was when the leaf was cut. However, in practice, the only important factor is for the operator to recognize when water just begins to appear at the cut end of the petiole.

The Plant Moisture Stress (PMS) reading at any given time reflects the plant’s interaction with the water supply and the demand for water placed upon the plant by its environment (see diagram on back cover). Since these factors are almost always changing, PMS is nearly always changing. The time of measurement therefore requires careful consideration — PMS is most at midday and least just before sunrise. Pre-sunrise PMS values will usually reflect average soil moisture tension, if the soil is uniformly irrigated. Midday PMS values reflect the tension experienced by the plant as it pulls water from the soil to satisfy the water demand of the atmosphere.

GETTING STARTED

The instrument is complete with a 20 Cubic Foot Portable Nitrogen Tank. The Tank is fitted with a CGA-580 Nitrogen Valve which is standard for US Nitrogen Service.

Tank is rated for a maximum pressure of 207 Bar/3000 PSI. The tank may be safely filled by using the “Trans-filling” method described in “Filling the Portable Tank” or having it filled at a Gas Supply Store. The instrument is designed for use with nitrogen (N₂). Welding Grade is sufficient. Maximum pressure in the Portable Tank or any tank connected to the instrument should not exceed 207 Bar/3000 PSI.

If the tank has not yet been filled, consult the tutorial on filling the tank.

USING THE PRESSURE CHAMBER

1. Turn the **Control Valve** to the “**OFF**” position.
2. **Slowly** open the valve on the Portable Tank. One-half to one turn is normally sufficient. Pressure will register in the Tank Pressure gauge. If tank is empty refer to Filling Portable Tank tutorial.
3. Turn on the Digital Gauge. (Press on/off button)
4. Check the **Safety Valve** and set the **Rate Valve** using the following procedure.

5. Remove the lid from the chamber by turning the lid counter-clockwise and lifting. Place a solid rubber stopper inside the recessed area under the lid as shown. Put the lid back on the chamber by pushing down and turning clock-wise to the stop. Lid must be turned completely to the stop to close the brass Safety Valve. If the stainless steel piston is not depressed, chamber will not pressurize. This is a safety feature of the instrument to ensure lid is properly seated.



Turn **Control Valve** to **CHAMBER** position and pressurize the chamber. Adjust **Rate Valve** until pressure in the chamber increases at the desired rate. ½ Bar per second is a recommended rate of increase. Rate may be changed at any time, even while pressurizing a sample.

CAUTION

Do not close Rate Valve completely or use as a Shut-Off Valve.

Valve may be damaged as a result.

6. Turn the **Control Valve** to **EXHAUST** position to release pressure from the chamber. Remove the lid and solid rubber stopper from the inside of lid. You are now ready to take readings.



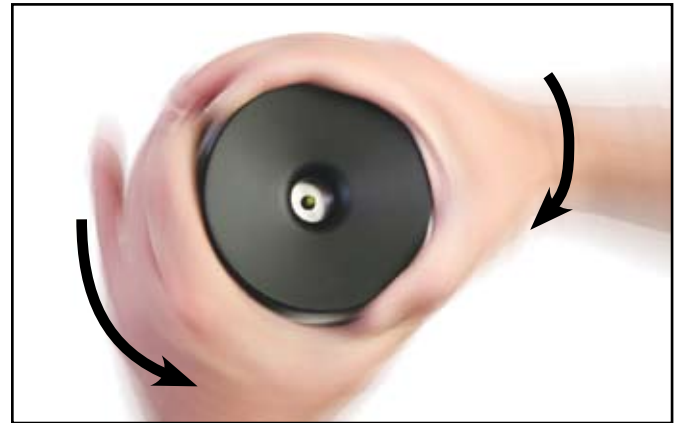



7. You can now select a leaf to test. To seal the sample, insert the cut end of the petiole (stem) through the hole from the bottom side of the chamber lid. Twist the **Compression Screw** clockwise to seal the sample in the lid. For more detailed information about sampling – consult our website.



DIGITAL GAUGE OPERATION

KEYPAD OPERATION

There are three buttons on the keypad, which function as follows:

- ① Power On-Off / Enter 
- ② Zero  Up Arrow  Tare **TARE**
- ③ Menu Selection  Down Arrow 
Backlight Arrow 
- ④ Key presses are **short** \rightarrow less than 0.5 seconds or **long** \dashrightarrow greater than 0.5 seconds.

LCD DISPLAY FUNCTIONS:

- ① 5 numerical digits for pressure display.
- ② 20 segment pressure range bar graph each segment equals 5% or range.
- ③ Sleep and Backlight Timer symbols.
- ④ Maximum / Minimum Pressure and Tare icons.
- ⑤ 5 character alpha-numeric digit display.
- ⑥ 4 segment battery life indicator.
- ⑦ Negative pressure indicator.

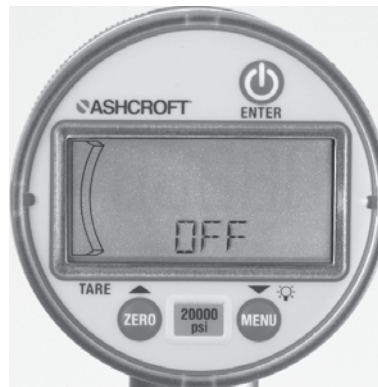
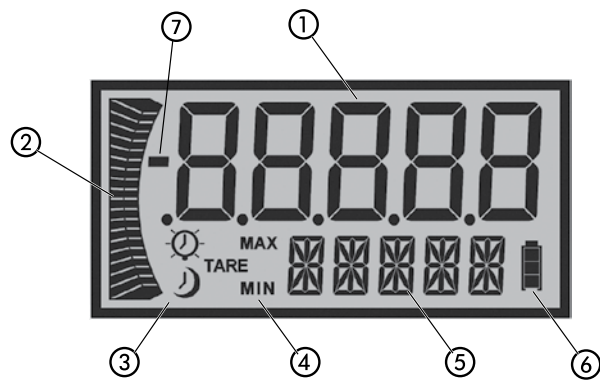
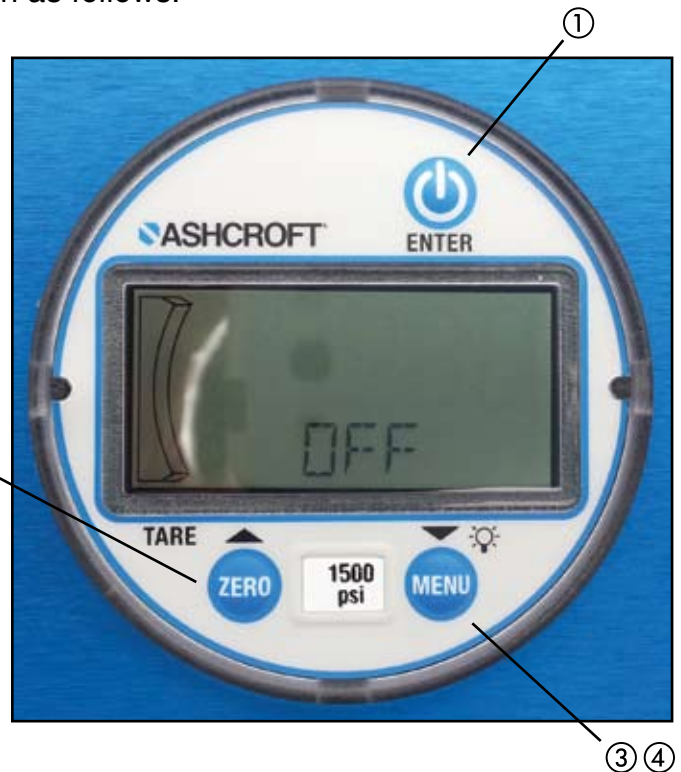

Turn the Gauge ON/OFF

Press  \dashrightarrow key to turn instrument ON / OFF. When initially turned ON, the display will momentarily show all LCD segments lit, product version and full scale range; the unit will then proceed automatically to the Measurement Mode.

Zero Function:

Press  \dashrightarrow . Upon release, the numeric display momentarily disappears and "ZERO" shows in alpha display, then returns to measurement mode. The pressure should now read 0. Zero value is stored in memory.

Note 1: A display message of "RLOCK" indicates that zero is more than $\pm 5\%$ from factory calibration. Zeroing is not possible.

Note 2: A message of "ZLOCK" indicates that zero lock function is activated.





Programming:

To enter menu mode

- ① Press **MENU** and release to proceed to programming mode.
- ② Press **▲**, **▼**, to scroll through programmable menu options.
- ③ When desired option is reached press **⏏** to access that parameter.
- ④ If at any time you choose to EXIT the menu mode (or sub-menu mode) hold **MENU**. Your work will not be saved.

Programmable Parameters:

Units of Measure:

- ① In Menu mode, press **▲**, **▼**, to scroll to "UNITS", press **⏏**.
- ② Choose engineering units by scrolling **▲**, **▼**, until desired unit is displayed, "PSI, BAR, kg/cm, kPa, mPa, Fth₂O, InHg, cmHG, mmHg, customer defined units (CUSTO)".
- ③ Press **⏏** to select units and return to Measurement Mode.

Maximum / Minimum:

Displays maximum / minimum pressure values; this is initiated upon powering the unit or since the values were cleared.

- ① When in menu mode press **▲**, **▼**, to scroll to 'Max' (maximum display); this is indicated in small font to the left of the display's unit of measure.
- ② To clear *both* Min and Max values, press and hold **ZERO**.
- ③ Release of this key will leave you in Menu mode. Use **▲**, **▼**, to continue scrolling through the menu options, OR hold, **MENU** to return to measurement mode.



Note: Clearing Minimum / Maximum values will reflect a blank display except for the associated Min. / Max. icon and battery indicator.

Note: The following actions will also clean min/max values. Power off, zero gauge function, tare function, field calibration function, units programming, update rate, or reset.

Timer:

Controls how long the gauge will remain powered ON once the Power key **⏏** is pressed.





- ① When in menu mode press **▲**, **▼** to scroll until "TIMER" is displayed.
- ② Press **⏏**.
- ③ Then, press **▲**, **▼** to scroll through values. "NONE" designates that the gauge will remain ON until the power key **⏏** is pressed a second time. Any other value (1 min [default] / 5 min / 20 min), other than "NONE", will designate the duration of time this function will be in effect.
- ④ Press **⏏** to select desired value; timer icon will be shown on the display and the unit will display "DONE" then return to Measurement Mode.

Feature: Timer icon will flash 10 seconds prior to gauge shut down.



Light:

Determines how long the back light will remain ON after any key is pressed in Measurement or Menu Modes (Note: The timer is reset with any key being pressed.)

- ① While in Menu mode press ,  until "LIGHT" is displayed.
- ② Press  for timer value to appear; "ON" refers to the back light remaining ON at all times unit is powered ON, "PRESS" designates that the back light is switched on / off by briefly pressing the backlight  whereas, "OFF" indicates the back light will never be illuminated. Selecting time values, "1 MIN" (default), "5 MIN", "20 MIN", will activate the backlight symbol on the LCD display for the designated minutes.
- ③ Press  to select back light time (display will briefly show "DONE") and return to Measurement Mode.









Note: In "PRESS" mode; factory has set 1 hour timer to save battery. **Feature:** Back light indicator will blink 10 seconds prior to light shut off.



Update:











Utilized to select the rate at which the displayed pressure value is updated on the screen. This function is used when rapid changes in pressure cause "flutter" in the display values; longer intervals will reduce the update rate and "average" the readings on such applications.

- ① In Menu mode, press ,  until "UPDAT" appears.
- ② Press  to select.
- ③ Press ,  to select values for "1 SEC" (default), "500 MSEC", or "250 MSEC".
- ④ Press  to select value (display will briefly show "DONE") and return to Measurement Mode.



Note: Changing value to anything other than 1 sec may cause a slight zero offset, and it is recommended that the gauge be fully vented and re-zeroed before taking accurate readings. Also battery life will be reduced by use of an update rate faster than 1 SEC.

Re-Calibration:

Provides the user the ability to field calibrate the product. Original factory calibration is permanently retained in memory and can be recalled at any time.

- ① In Menu mode, press ,  until "RECAL" appears, proceed to press .
- ② Display will indicate "FACT" (factory) "FIELD" or "NEW" press ,  to scroll.
- ③ Pressing  while "FACT" (factory) is displayed will restore values of factory calibration.
- ④ Pressing  when "FIELD" is displayed will restore values from latest field calibration.
- ⑤ Pressing "Enter" key  when "NEW" appears will enter the recalibrate mode.
- ⑥ When "NEW" is displayed, press ; upon release, the display will flash "OK/APPLY/REF/PSI/THEN/PRESS/ENTER/TO/START/OR/OTHER/TO/ABORT". Numeric display will read .00000. Vent sensor to atmospheric pressure, press  display will show "WAIT" and count down from 6 seconds then briefly display CAL then automatically go to next step.
- ⑦ Display flashes "APPLY/REF/PSI/THEN/PRESS/ENTER/TO/START/OR/OTHER/TO/ABORT"; apply the full scale pressure in units of psi indicated in numeric display to gauge. Press  display will show "WAIT" and count down from 6 seconds then briefly display CAL then automatically go to next step.





- ⑧ Display flashes “APPLY/REF/PSI/THEN/PRESS/ENTER/TO/START/OR/OTHER/TO/ABORT”; apply the pressure indicated in numeric display to gauge and press  → display will show “WAIT” and count down from 6 seconds then briefly display GOOD then exit into measurement more, or
- ⑨ COMPOUND RANGE GAUGES ONLY REQUIRE ONE ADDITIONAL CALIBRATION POINT NEAR VACCUUM.
- ⑩ Display flashes “APPLY/REF/PSI/THEN/PRESS/ENTER/TO/START/OR/OTHER/TO/ABORT”; apply near vacuum of -14.000 psi as indicated in numeric display to gauge and press , display will show “WAIT” and count down from 6 seconds then briefly display “GOOD” then exit into Measurement Mode.

Note: Recalibration is allowed only if test parameters are within ±7%. If outside this window, the display will indicate “CAL FAIL / INPUT PRES TOO LOW (HIGH) / PRESS ENTER TO RETRY / PRESS OTHER TO ABORT”.

Note: “FIELD” option appears only if gauge has been successfully field recalibrated.

Reset:

Returns the product to the factory values. Preserves field calibration. Factory calibration can be restored in the “RECAL” menu.

- ① In Menu mode, press ,  → until “RESET” appears on display’s lower line;  →.
Factory defaults pertain to units, timer, back light, update rate, zero lock. Display will indicate “DONE” then gauge will switch to “OFF” condition.



Changing Batteries:

- ① Grip knurled back cover and rotate counter-clockwise until the ‘unlock’ icon is in alignment with the arrow — this is on the housing at the base of the pressure connection.
- ② Remove cover by pulling straight back and replace AA alkaline batteries accordingly; ensure that the batteries are in the proper polarity position.
- ③ For reattachment of cover, align the ‘unlock’ icon with the arrow, push cover straight in then turn clockwise until the arrow is in alignment with the ‘Lock’ icon.

Note: Reinstallation of the back cover may cause the unit to read negative pressure. This is a temporary issue as the internal case pressure will be relieved by the case vent and equalize with atmospheric pressure (90% of the offset will equalize within 1 minute, the remaining 10% may take up to 5 minutes).

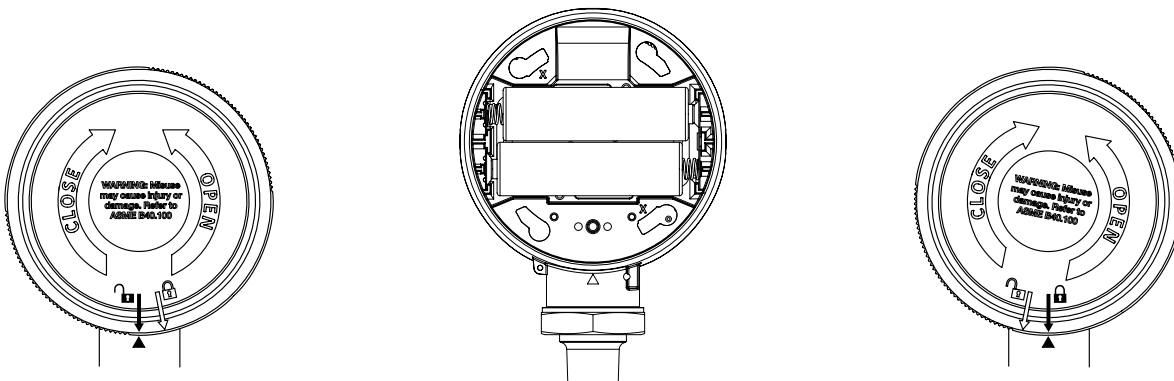

WHEN YOU HAVE COMPLETED MEASUREMENTS

- 1. Close the Valve on the Portable Tank.

For a complete list of picture tutorials and videos - www.pmsinstrument.com



FILLING THE PORTABLE TANK

In order to successfully fill the Portable Tank, the following items are needed:

1. 6-Foot Filling Hose.
2. Nurse Tank (Large Tank).
3. Model 1515D Pressure Chamber Instrument.

1. Ensure the **Portable Tank Valve** is closed. Check the **Tank Pressure Gauge** to ensure it reads zero and that there is no pressure in the instrument or **Tank Hose**. If there is still pressure, remove the lid of the instrument and cycle the **Control Valve** to **Chamber** position.

2. Detach the **Tank Hose** by releasing the quick coupler.

3. Connect the end of the **6-Foot Filling Hose** to the **Tank Hose**.

4. Connect the other end of the 6-Foot Filling Hose to a Nurse Tank that has 207 Bar/3000 PSI or less pressure in it.



5. Ensure that the **Control Valve** is in the **"OFF"** position.



6. Ensure that the **Nurse Tank Valve** is completely closed.



7. Ensure that the **Purge Valve** on the 6-Foot Filling Hose is completely closed.



8. Ensure that the **Portable Tank Valve** is completely closed.



9. The system should now look like this.

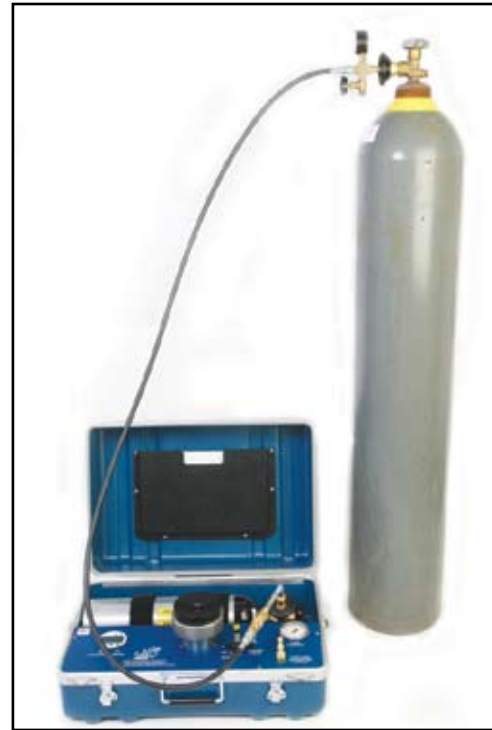

10. Next, open the valve on the **Nurse Tank** slowly.



This allows pressure down to the **Portable Tank** and you can verify quantity of pressure in **Nurse Tank** by looking at the 6-Foot Filling Hose gauge..



11. Next, open the **Portable Tank Valve** — just barely. 1/6 of a turn at first and you will hear the gas begin to enter the tank. Wait for the gas to equalize. When the noise stops, simply open the **Portable Tank Valve** a little more. Eventually you will have the valve completely open. The whole process should take about 4-5 minutes.



CAUTION

Ensure you fill the tank slowly.

Filling it too quickly will cause the valve to heat up and can cause damage to the valve.

12. Now the tank is full, close the **Portable Tank Valve**. Close the **Nurse Tank Valve**.
13. Open the **Purge Valve** on the 6-Foot Filling Hose to release the pressure from the hose.
14. Disconnect the 6-Foot Filling Hose from Tank Hose and Nurse Tank.
15. Reconnect the **Portable Tank Hose** to the **Tank Hose Connection** and give it a tug to ensure properly connected.

Testing the Safety Valve

The instrument is fitted with a Safety Valve to ensure that the lid is properly seated prior to pressurizing the chamber. The Safety Valve will vent the chamber if the lid is not properly closed. **This valve MUST be tested at the beginning of each measurement session.**

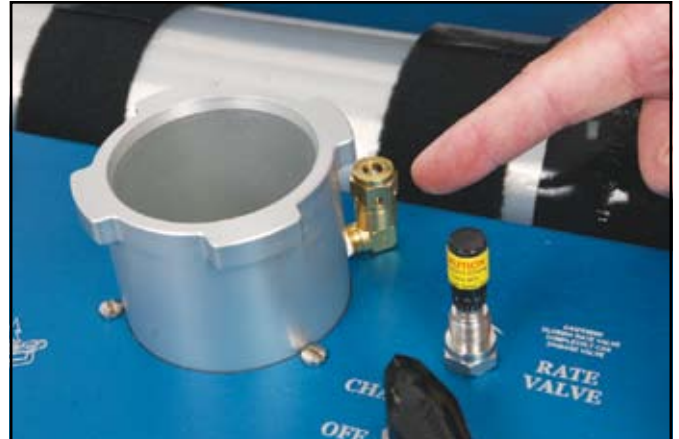

First, use your finger to depress the piston so that it is inside the safety valve

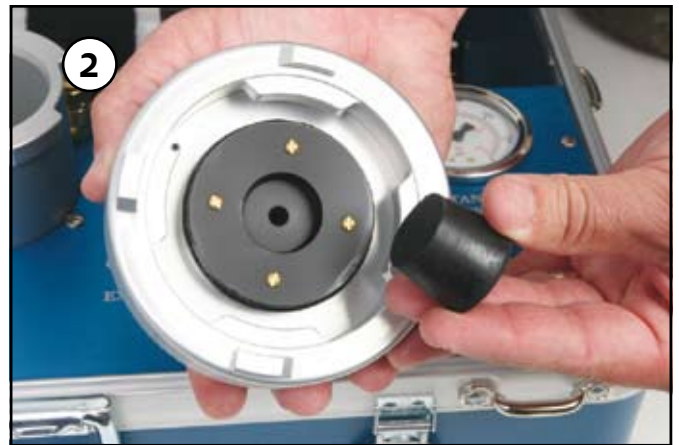

Insert a solid rubber gasket into the lid

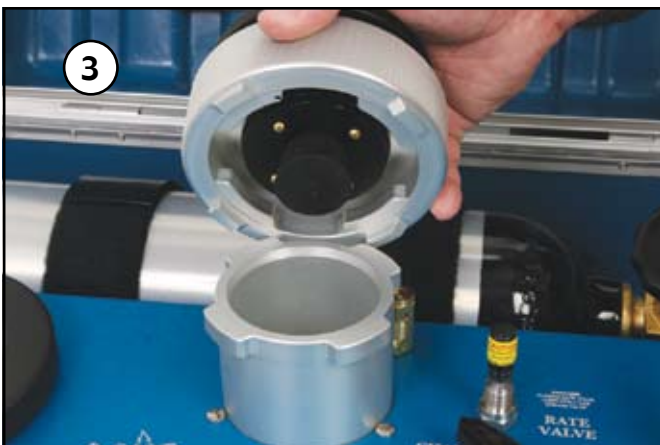

Install the lid on the chamber



Turn the lid clockwise to the stop. Ensure the cam is directly over the piston

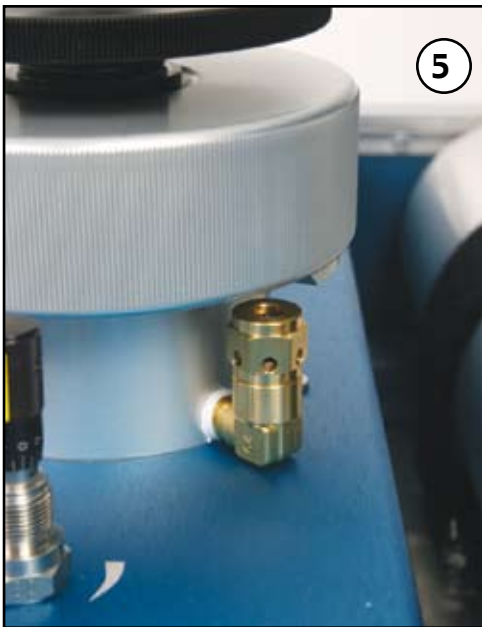

Then turn the lid back so that the cam is not blocking the piston



Begin to slowly apply pressure to the chamber

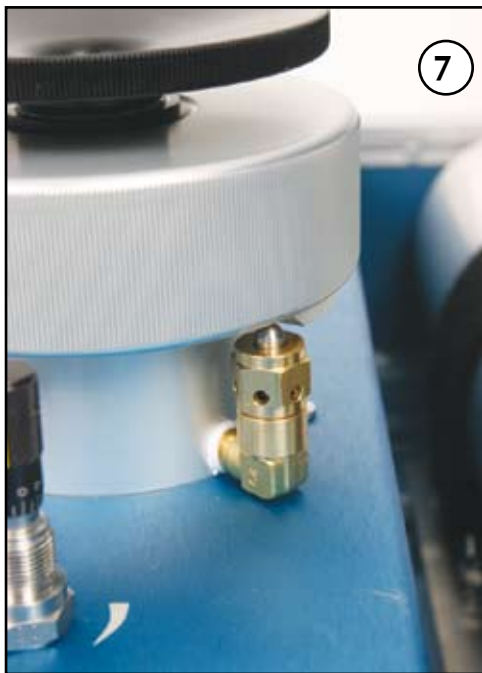

The safety valve should pop open before the pressure reaches 2 bar

SAFETY VALVE

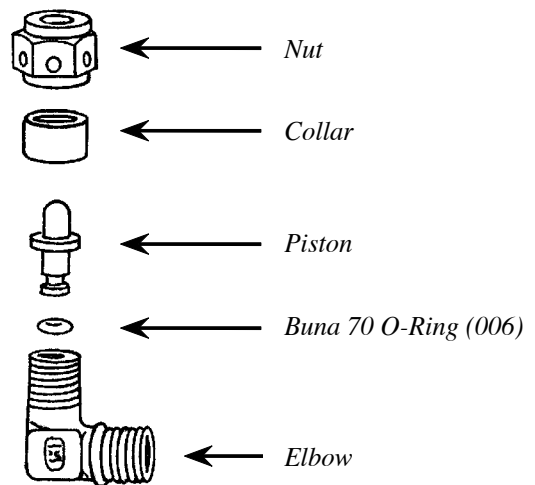

You will hear nitrogen escaping from the valve and the pressure will not increase in the chamber. If it does not, turn the control to EXHAUST, then remove the nut and piston of the safety valve and lubricate the O-ring on the piston with petroleum jelly. Reassemble and test the safety valve again. When the safety valve opens, the pressure in the chamber should drop to near zero. This time the safety valve should open at a pressure below 2 bar. If it does not, remove the nut and piston of the safety valve and again clean and lubricate the O-ring on the piston with petroleum jelly. Check for any foreign debris then reassemble and test the safety valve again.

The safety valve is an important safety component of the instrument. Do not attempt to operate the instrument until the safety valve is operating properly; that is, until it is releasing the chamber pressure at less than 2 bar pressure,

As an added safety precaution, the cover should be left in only one of two positions:

1. On the chamber and completely locked in place; or
2. Completely removed from the chamber.

The lid should never be left in any intermediate position.

INSTRUMENT MAINTENANCE

- 1) Remove the O-Ring from around the lid. Clean with rag and lubricate with Petroleum Jelly for optimal performance.
- 2) Remove the Compression Gland Screw from the lid. Clean the threads of the Screw and the Compression Gland Base with a rag. Lubricate this with Lithium Grease (White Grease) for optimal performance.
- 3) Compression Gland Gasket can be cleaned with a rubber treatment such as used with automobile detailing (Armour All brand) for optimal performance. When Compression Gland Gasket becomes worn – replace with new gasket for optimal performance.



CONTROL VALVE ADJUSTMENT

The control valve will need periodic adjustment depending upon usage. Adjustment is required if leakage occurs in the pressurized instrument with the control valve in the OFF position. Two tools are needed and have been provided with your instrument. A 3/32 inch Allen Key is used to remove the Control Valve Handle. A 11/32 inch wrench is used to adjust the packing on the valve.

1. Pressurize the instrument with the control valve in the OFF position.
2. Loosen the hex screw with the Allen Key. It is located on the side of the Control Valve Handle.
3. Using the 11/32 wrench, slowly tighten the packing gland nut until the leak stops.

CAUTION

Do not overtighten the packing gland!

Permanent damage to the valve will result.

4. Replace the handle and tighten the hex screw.



For a complete list of picture tutorials and videos - www.pmsinstrument.com

Maintenance for Compression Gland Lid

Maintaining the Compression Gland Lid is quite simple. Keep the O-ring around the Compression Gland Insert clean and lubricated with petroleum jelly. Occasionally unscrew the compression screw and take out the Compression Gland Insert and Compression Gland Gasket inside for cleaning. We recommend lubricating the compression screw threads with a Lithium based lubricant such as white grease or other lubricant to maintain the threads and ensure easy operation. Keeping these threads clean is important for ensuring operability of the cover. Clean the Compression Gland Gasket with ARMOR ALL or other similar cleaner. Over time the compression gland gasket will become worn, a replacement has been supplied for your convenience. If additional gaskets are needed, you may purchase them directly from PMS Instrument Company.

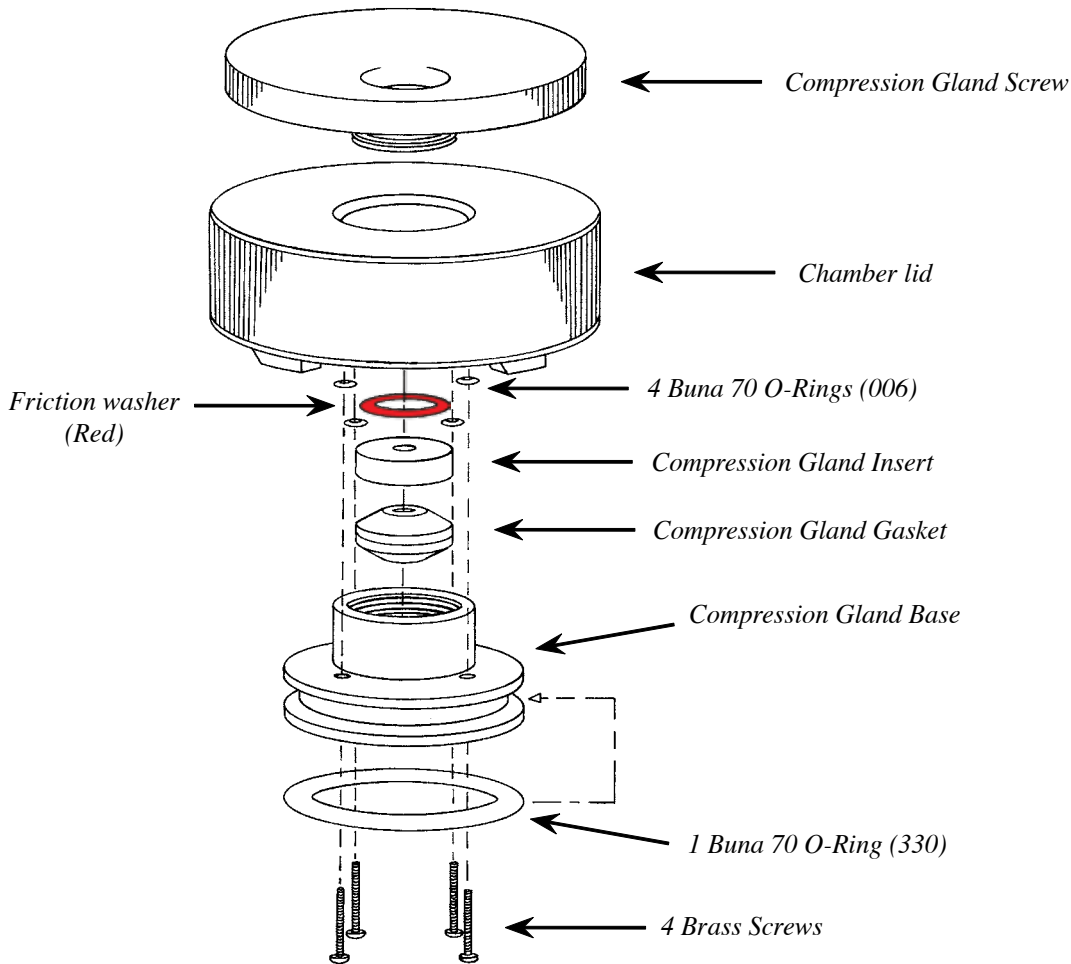

TO RE-ASSEMBLE THE COMPRESSION GLAND START BY:

1. Sliding the Compression Gland into the Chamber Lid
2. Insert the 4 brass screws and screw the insert down tight — make sure that the 4 small O-rings are in place first
3. Put the Compression Gland Gasket into the Compression Gland Base
4. Put the Compression Gland Insert on top of the gasket and the Friction Washer on top of the Compression Gland Insert
5. Be sure to lubricate the threads and screw the Compression Screw into the Compression Gland Base
6. The Compression Gland Cover is now ready for use

Warnings, Considerations and Limits

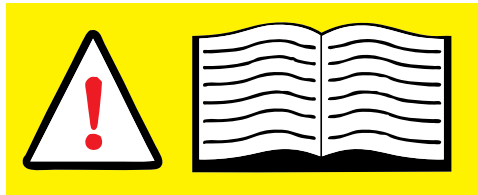

Intended Usage

The Pressure Chamber Instrument usage is intended for applying pressure to plant material to determine water potential or to extract water xylem from plants. It should not be used to pressurize anything other than plant material. Using this instrument for any other purpose or in an unsafe manner could result in harm to the user.

Upon receiving the instrument or using it for the first time, each user should familiarize themselves thoroughly with all safety features and set-up process to avoid damage of instrument or physical injury to operator.

Working Environment

The instrument is robust and durable and designed for outdoor use. It may be used in temperatures as high as 55° C and as low as –10° C. It is best to store inside where temperatures do not exceed 40° C or lower than 0° C. Keep in clean and dry area. Store on a flat surface that is protected from being struck or damaged. Normal vibration during use will not affect performance of the instrument such as travel in vehicle or all terrain vehicles. Excessive shaking and vibration can cause damage. If the instrument has received a hard blow or hit, it should be evaluated prior to further use. The instrument is not vulnerable to humidity but should never be submersed in water. If the instrument becomes submersed, allow it to dry and evaluate the instrument prior to further use.

Transporting Instrument

Transporting the instrument by any mode should be done with care as not to strike the instrument against anything hard as this might damage the instrument. If transporting by vehicle such as truck, car or all terrain vehicle; the instrument should be securely fastened in order to avoid any damage to the instrument.

Maintenance

Most maintenance issues can be done without much training. Consult the maintenance pages in this manual. However, any adjustments to piping or high pressure connectors should only be performed by factory or authorized personnel. Consult us directly for more information.

Disposal or Decommission of the Instrument

While the instrument should provide years of use, it is possible that sometime it will be disposed of. Local recycling guidelines should be followed for disposal.



PMS Instrument Company

1725 Geary Street SE ♦ Albany OR 97322

Phone: (541) 704-2299

FAX: (541) 704-2388

E-mail: info@pmsinstrument.com

www.pmsinstrument.com

EU Declaration of Conformity

We,

*PMS Instrument Company
1725 Geary Street SE
Albany, OR 97322 USA*

Declare under our sole responsibility that the following products:

Pump-Up Chamber, 600 Pressure Chamber, 605 Pressure Chamber, 615 Pressure Chamber,
615D Pressure Chamber, 1000 Pressure Chamber, 1005 Pressure Chamber, 1000
“upgraded to 100 Bar” Pressure Chamber, 1005 “upgraded to 100 Bar” Pressure Chamber.

In addition, the following accessories are included:

Cavitation Chamber

To which this declaration relates is in conformity with the following Standards or other normative documents:

EN ISO 12100-1:2003, EN ISO 12100-2:2003, 97/37/EC Annex I

Following the provisions of Directives;

98/37/EC, 97/37/EC (Equipment is below class I limits per the PED)

Responsible party in the European Union: _____

Place: Elancourt, France

Date: May 6, 2009

President, PMS Instrument Company: _____

Place: Albany, Oregon, USA

Date: May 6, 2009

Officer: Jean-Luc AVERLAN
Sols Mesures

Officer: Jeff Hamel, President
PMS Instrument Company

SOLS MESURES
17, rue Jean Monnet - BP 44
78990 ELANCOURT - FRANCE
Tel. 01 30 50 34 50 - Fax 01 30 50 34 49
info@sols-mesures.com
www.sols-mesures.com

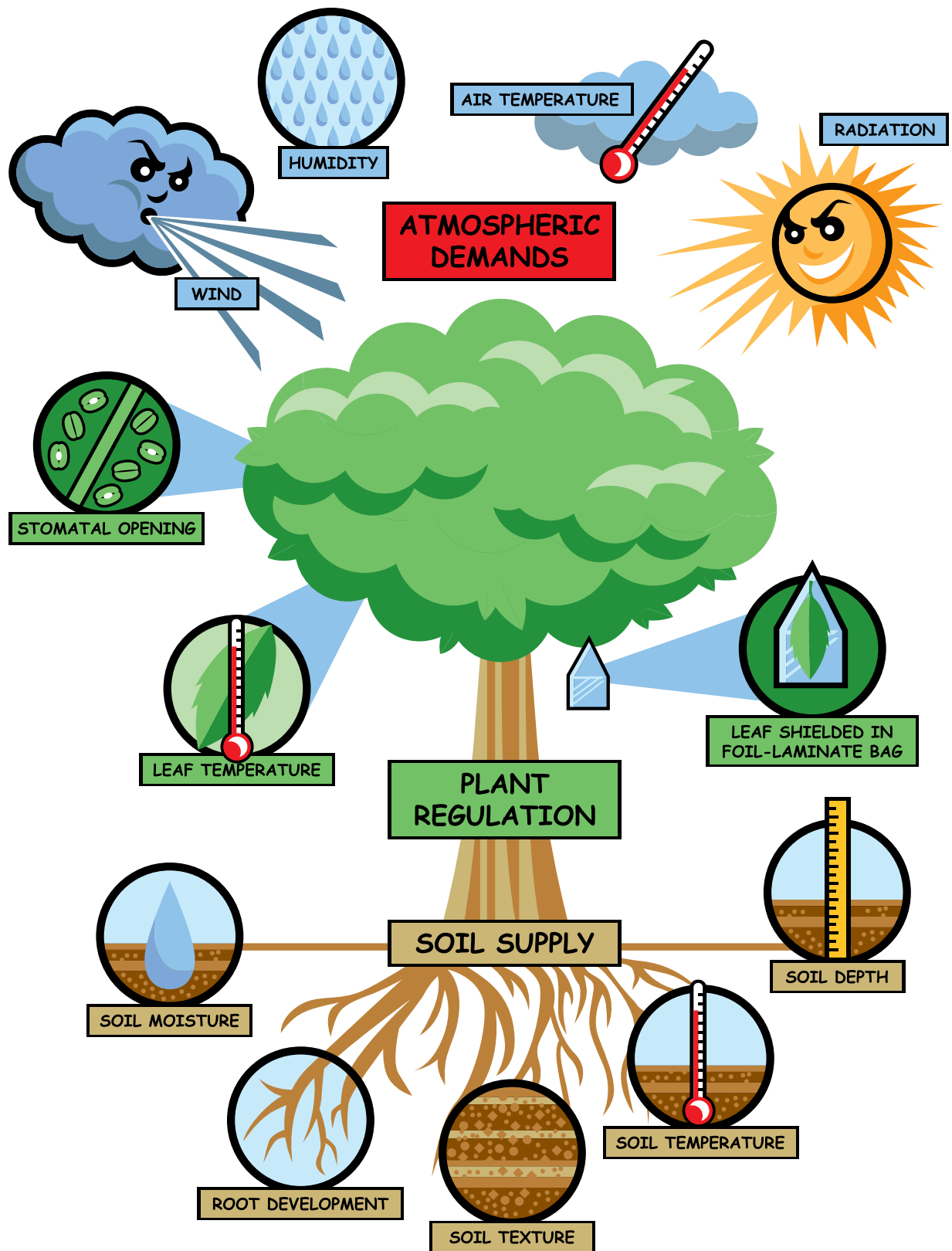

Atmospheric Demands: The atmosphere of the plant puts four different demands on the plant: wind, humidity, air temperature, and radiation.

Plant Regulation: The plant regulates water stress by opening and closing the stomata (small holes) on the backside of the leaf. Other regulators used are leaf flagging, rolling and leaf loss. Good root development is also key in regulating water stress.

Soil Supply: Soil composition is critical for the plant. Moisture content is a key factor in PMS. In addition, the temperature of the soil and depth will influence PMS. Depending upon the texture of the soil and how it holds moisture is another important aspect of the soil. Loose sandy soil will drain out moisture quickly while heavy clay will hold moisture longer.